

TUSS NOVEMBER 2024  
CLASS 2 & 3

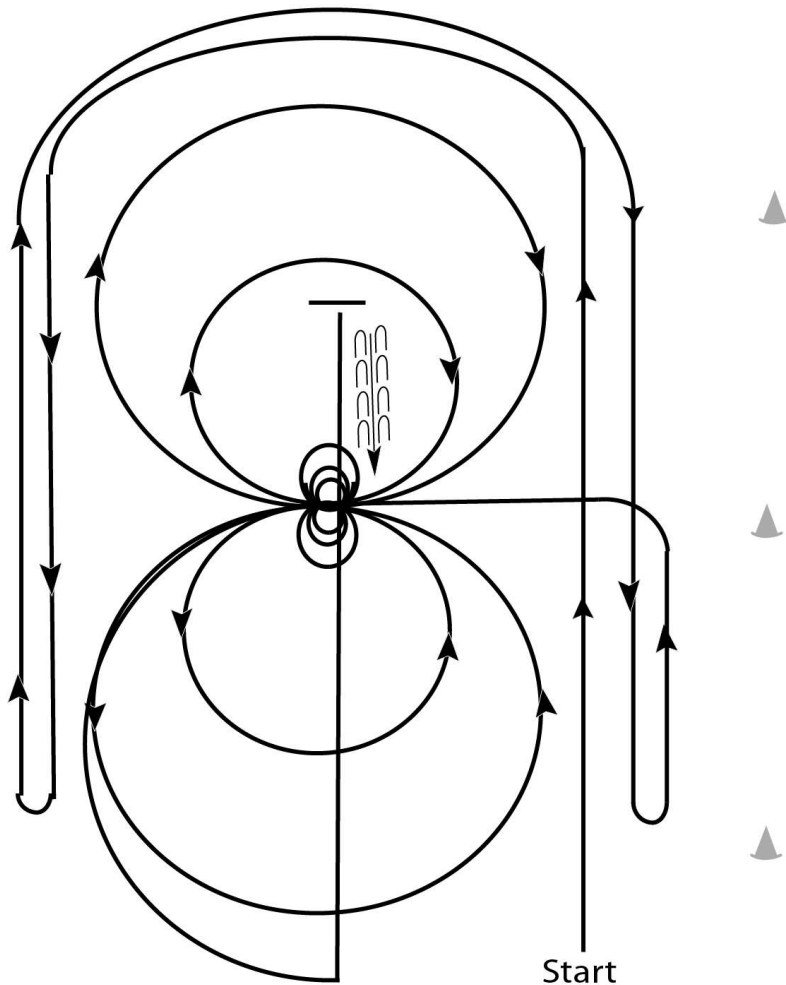

1. Beginning, lope straight up the right side of the arena, circle the top of the arena, run straight down the opposite or left side of the arena past the center mark and do a right rollback - no hesitation.
2. Continue straight up the left side of the arena circle back around the top of the arena run straight down the right side of the arena past the center marker and do a left rollback - no hesitation.
3. Continue up the right side of the arena to the center marker, at the center marker horse should be on the left lead and complete two circles to the left, one large fast and one small slow. Stop at center. Hesitate.
4. Complete three spins to the left. Hesitate.
5. Complete two circles to the right, one large fast and one small slow. Stop at center. Hesitate.
6. Complete three spins to the right. Hesitate.
7. Begin a large fast circle to the left, do not close this circle. Continue up the center of the arena past the center marker and do a sliding stop.
8. Back up at least ten feet. Hesitate to demonstrate completion of pattern.

[R/NRHAP-13]

**Pattern Provided by:**

# TUSS NOVEMBER 2024

## Reining CLASS 4

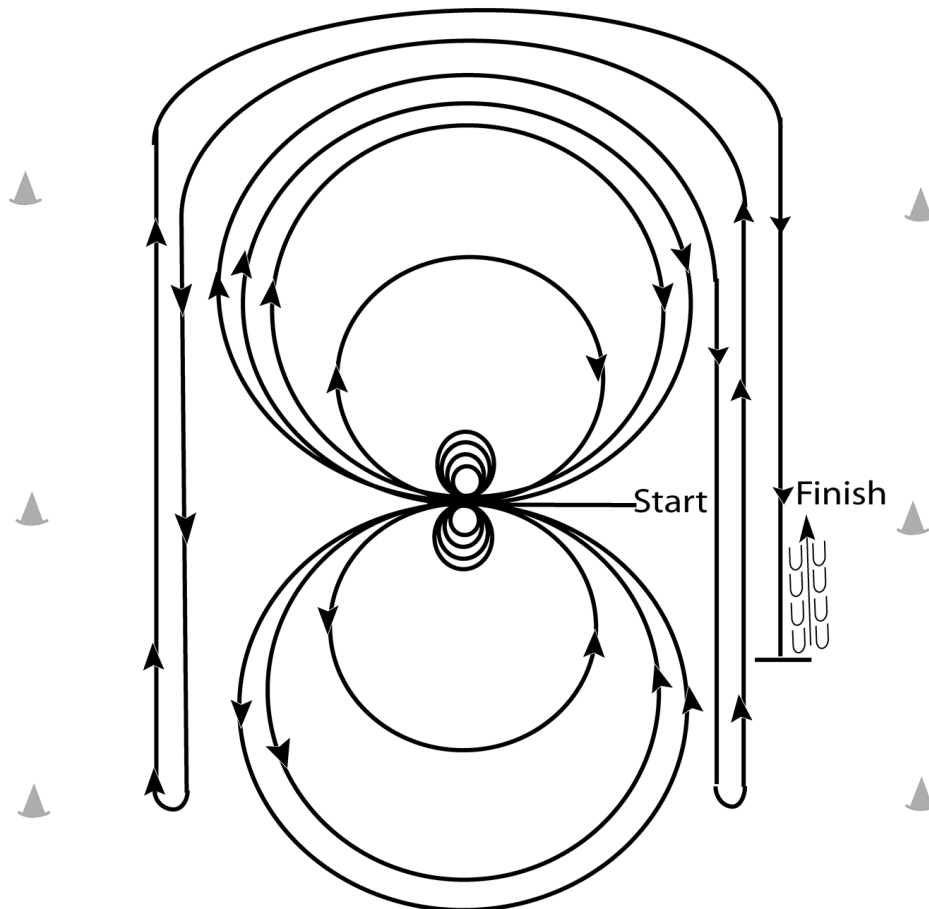

Horses may walk or trot to the center of the arena. Beginning at the center of the arena facing the left wall or fence.

1. Complete four spins to the left.
  2. Complete four spins to the right. Hesitate.
  3. Beginning on the right lead, complete three circles to the right: the first circle large and fast; the second circle small and slow; the third circle large and fast. Change leads at the center of the arena.
  4. Complete three circles to the left: the first circle large and fast; the second circle small and slow; the third circle large and fast. Change leads at the center of the arena.
  5. Begin a large fast circle to the right but do not close this circle. Run straight down the right side of the arena past the center marker and do a left rollback at least twenty feet (6.09m) from the wall or fence – no hesitation.
  6. Continue back around the previous circle but do not close this circle. Run down the left side of the arena past the center marker and do a right rollback at least twenty feet (6.09m) from the wall or fence – no hesitation.
  7. Continue back around the previous circle but do not close this circle. Run down the right side of the arena past the center marker and do a sliding stop at least twenty feet (6.09m) from the wall or fence. Back up at least ten feet (3m). Hesitate to demonstrate completion of the pattern.
- Rider may dismount and drop bridle to the designated judge.

[R/NRHAP-8]

**Pattern Provided by:**

# TUSS NOVEMBER 2024

## CLASS 1, WALK TROT REINING

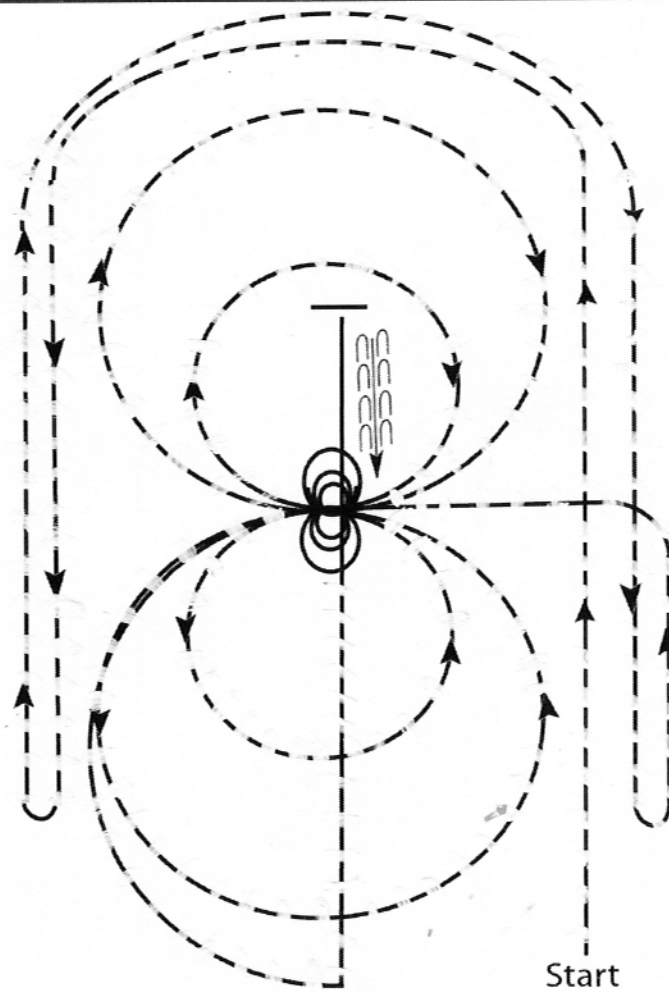

1. Start, extended trot straight up the right side of the arena, circle the top of the arena, trot straight down the opposite or left side of the arena past the center mark and do a right rollback - no hesitation.
2. Continue straight up the left side of the arena circle back around the top of the arena run straight down the right side of the arena past the center marker and do a left rollback - no hesitation.
3. Continue up the right side of the arena to the center marker, at the center marker horse should be heading left and complete two circles to the left, one large fast and one small slow. Stop at center. Hesitate.
4. Complete three spins to the left. Hesitate.
5. Complete two circles to the right, one large fast and one small slow. Stop at center. Hesitate.
6. Complete three spins to the right. Hesitate.
7. Begin a large fast circle to the left, do not close this circle. Continue up the center of the arena past the center marker and do a sliding stop.
8. Back up at least ten feet. Hesitate to demonstrate completion of pattern.

\*\*\*NOTE\*\*\* "Large Fast" = Extended Trot in a large circle "Small Slow" = Regular Trot in a small circle

[R/NRHAP-13]

TUSS NOVEMBER 2024  
**RANCH RIDING Walk Trot**  
 Class 5, 6, 7

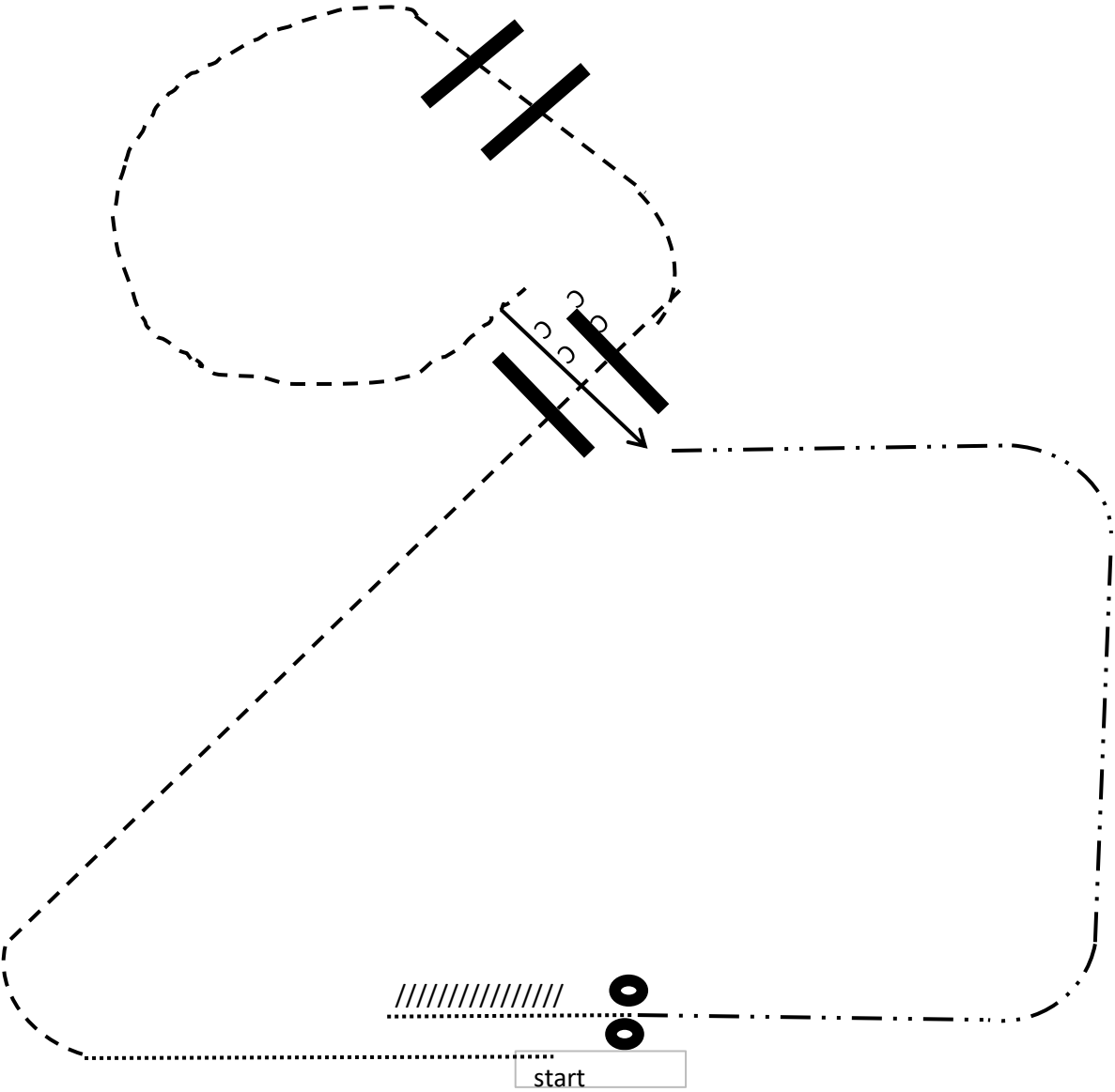

- |                     |                 |
|---------------------|-----------------|
| 1 WALK              | 5 EXTENDED TROT |
| 2 TROT              | 6 WALK          |
| 3 TROT over 4 RAILS | 7 STOP & BACK   |
| 4 SIDEPASS RIGHT    | 8 360 each way  |

WALK	-----
TROT	- - - - -
EXT TROT	-----

# RANCH RIDING

# TUSS NOVEMBER 2024 Classes 8 thru 10

## LEGEND

.....	Walk
....	Extended Walk
- - -	Trot
- - -	Extended Trot
— — —	Lope
— — —	Extended Lope
////	Back
\\	Lead Change

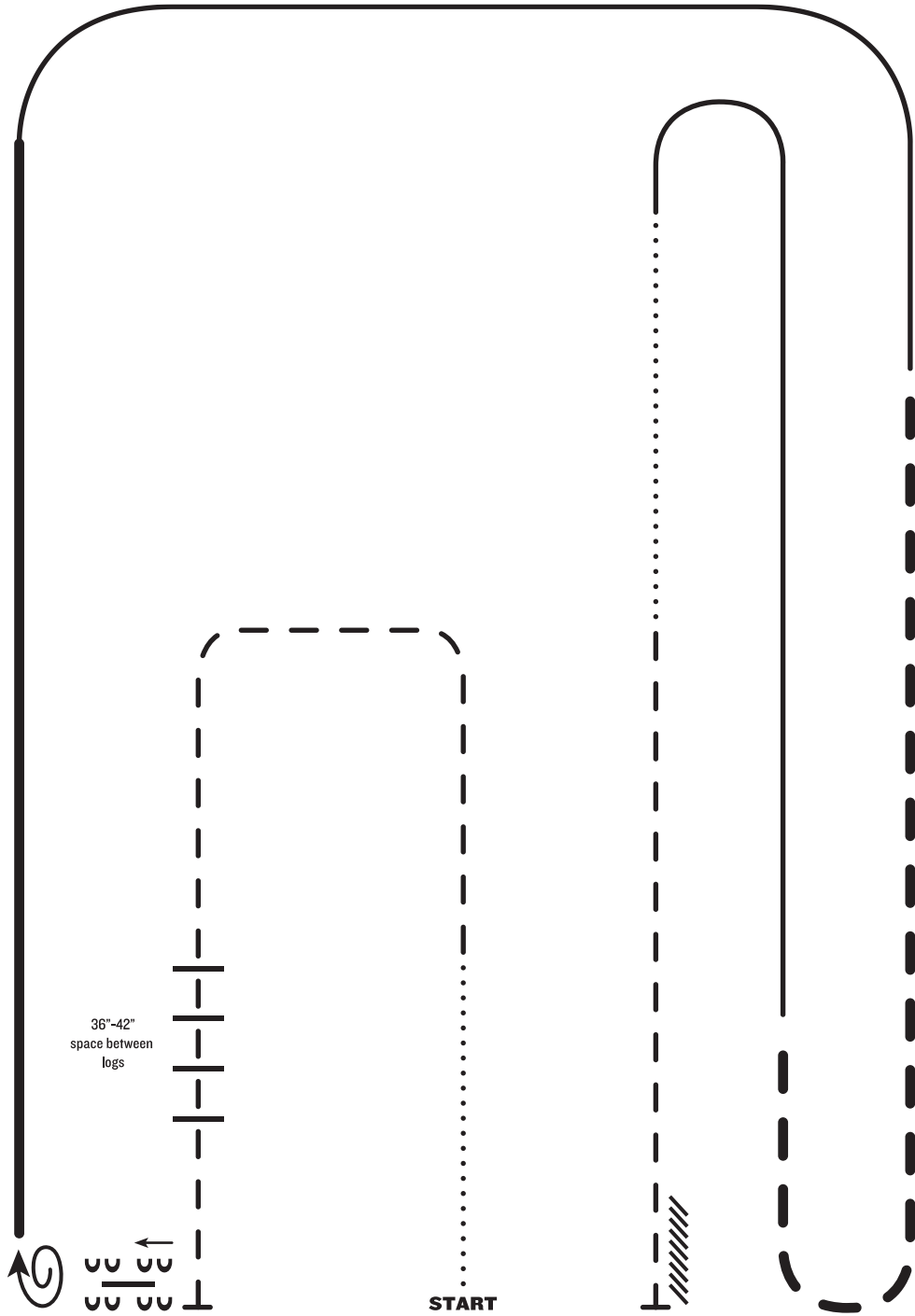

1. Walk
2. Trot
3. Trot over logs, stop
4. Side pass right over log
5. 1 1/2 turn right
6. Extended lope right lead
7. Lope right lead
8. Extended trot
9. Lope left lead
10. Walk
11. Trot
12. Stop and back

Note: The drawn description of this pattern is only intended for the general depiction of the pattern. Exhibitors should utilize the arena space to best exhibit their horses.