

TUSS MARCH 2025

REINING (W/T OPEN)

Show Date:

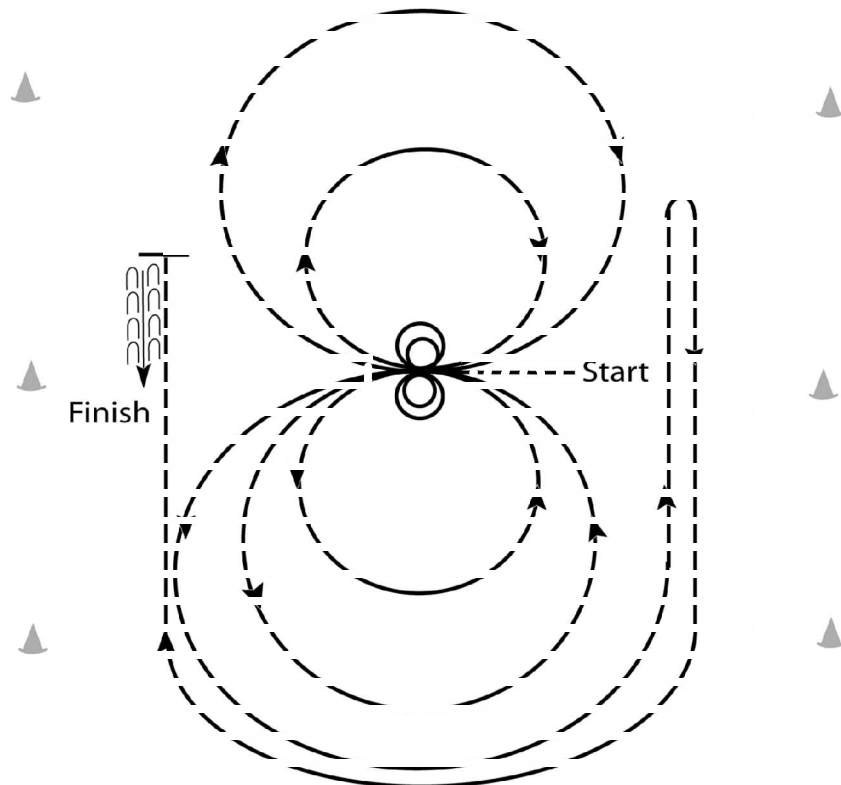

Horses may trot to the center of the arena. Horses must stop prior to starting the pattern. Begin at the center of the arena facing the left wall or fence.

1. Beginning to the left, complete two circles to the left. Small circle regular trot, large circle extended trot. Stop at the center of the arena. Hesitate.
2. Complete 2 spins to the left. Hesitate
3. Beginning to the right, complete two circles to the right. Small circle regular trot, large circle extended trot. Stop at the center of the arena. Hesitate.
4. Complete 2 spins to the right. Hesitate
5. Beginning to the left, extended trot around the end of the arena, extended trot down the right side of the arena past center marker, stop & roll back right
6. Extended trot around the end of the arena and extended trot down the left side of the arena past the center marker. Stop. Back up

TUSS MARCH 2025

REINING (OPEN)

Show Date:

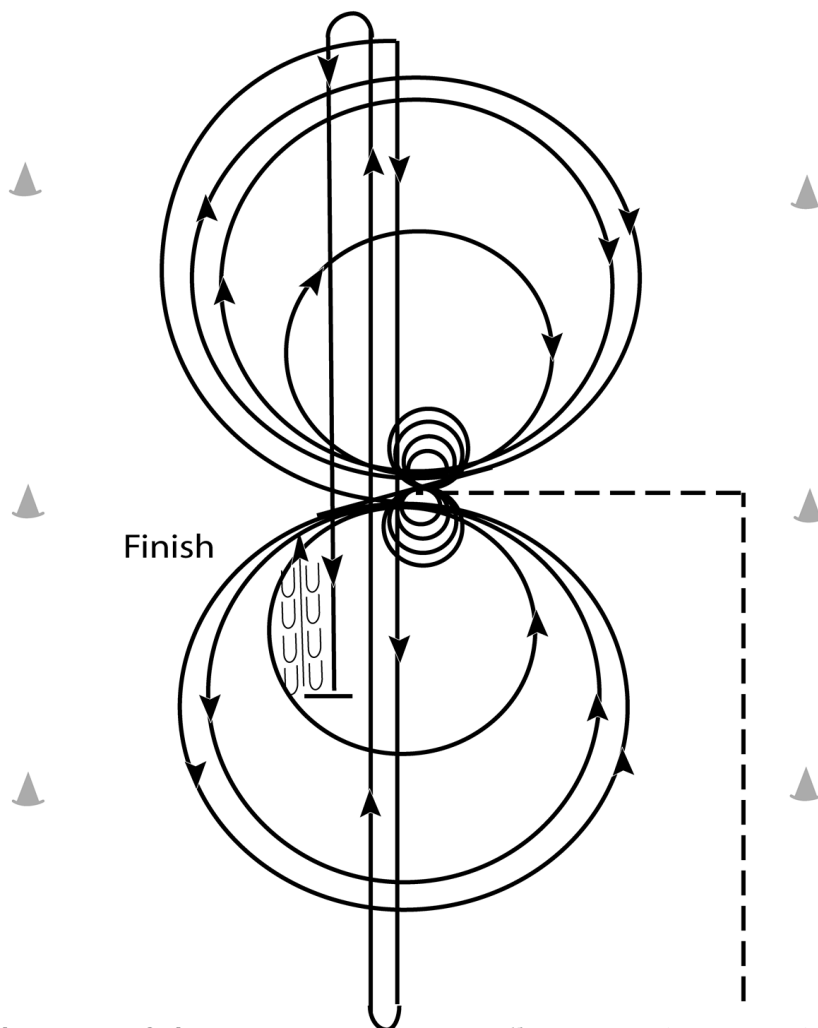

Horses must trot to the center of the arena. Horses must walk or stop prior to starting pattern. Begin at the center of the arena facing the left wall or fence.

1. Complete four spins to the left. Hesitate.
2. Complete four spins to the right. Hesitate.
3. Beginning on the right lead, complete three circles to the right; the first small and slow; the next two circles large and fast. Change leads at the center of the arena.
4. Complete three circles to the left; the first small and slow; the next two circles large and fast. Change leads at the center of the arena.
5. Begin a large circle to the right, but do not close this circle. Run down the center of the arena past the end marker and do a right rollback - no hesitation. C
6. Run up the middle to the opposite end of the arena past the end marker and do a left rollback - no hesitation.
7. Run past the center marker and do a sliding stop. Back up to the center of the arena or at least 10 feet (3m). Hesitate to demonstrate completion of pattern.

Rider must dismount and drop bridle to the designated judge.

[R/NRHAP-11]

Pattern Provided by:

TUSS MARCH 2025

Reining (GREEN HORSE/RIDER, YOUTH OR NON PRO)

Show Date:

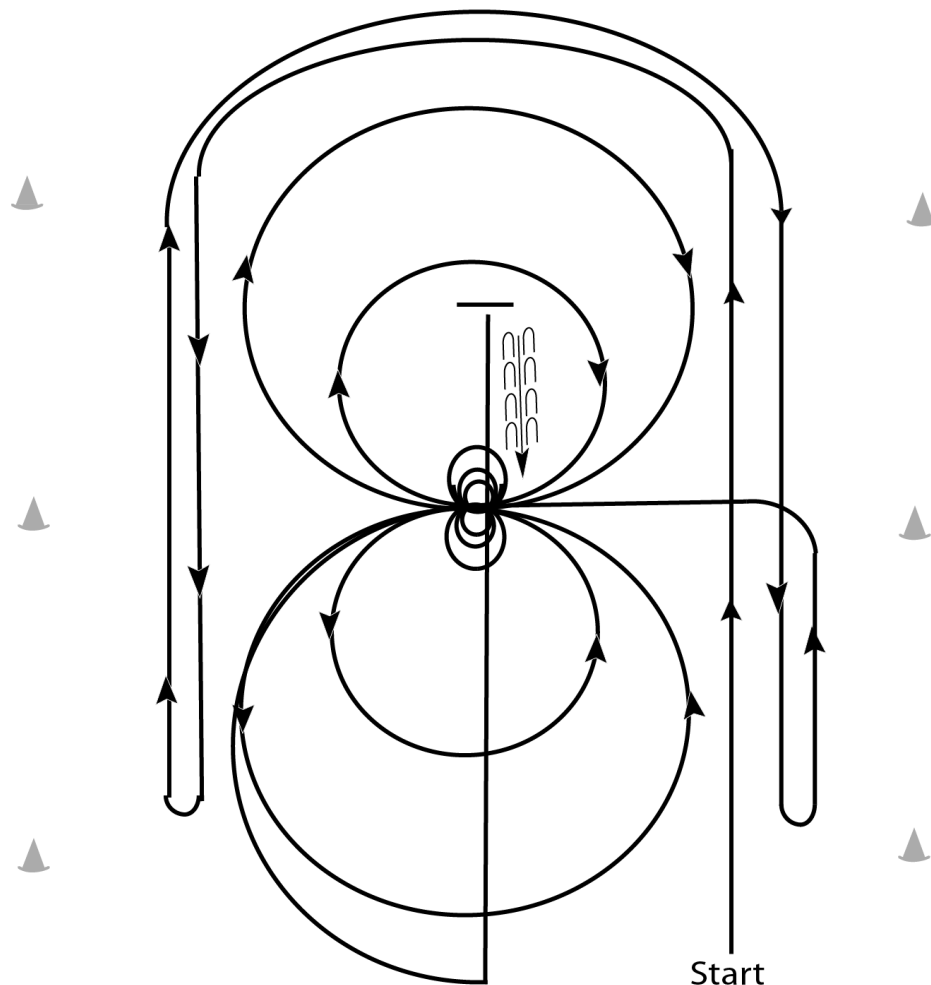

1. Beginning, lope straight up the right side of the arena, circle the top of the arena, run straight down the opposite or left side of the arena past the center mark and do a right rollback - no hesitation.
2. Continue straight up the left side of the arena circle back around the top of the arena run straight down the right side of the arena past the center marker and do a left rollback - no hesitation.
3. Continue up the right side of the arena to the center marker, at the center marker horse should be on the left lead and complete two circles to the left, one large fast and one small slow. Stop at center. Hesitate.
4. Complete three spins to the left. Hesitate.
5. Complete two circles to the right, one large fast and one small slow. Stop at center. Hesitate.
6. Complete three spins to the right. Hesitate.
7. Begin a large fast circle to the left, do not close this circle. Continue up the center of the arena past the center marker and do a sliding stop.
8. Back up at least ten feet. Hesitate to demonstrate completion of pattern.

[R/NRHAP-13]

Pattern Provided by:

TUSS MARCH 2025

W/T TROT RANCH RIDING (ALL W/T CLASSES)

Show Date:

w w w . H o r s e S h o w P a t t e r n s . c o m

w w w . H o r s e S h o w P a t t e r n s . c o m

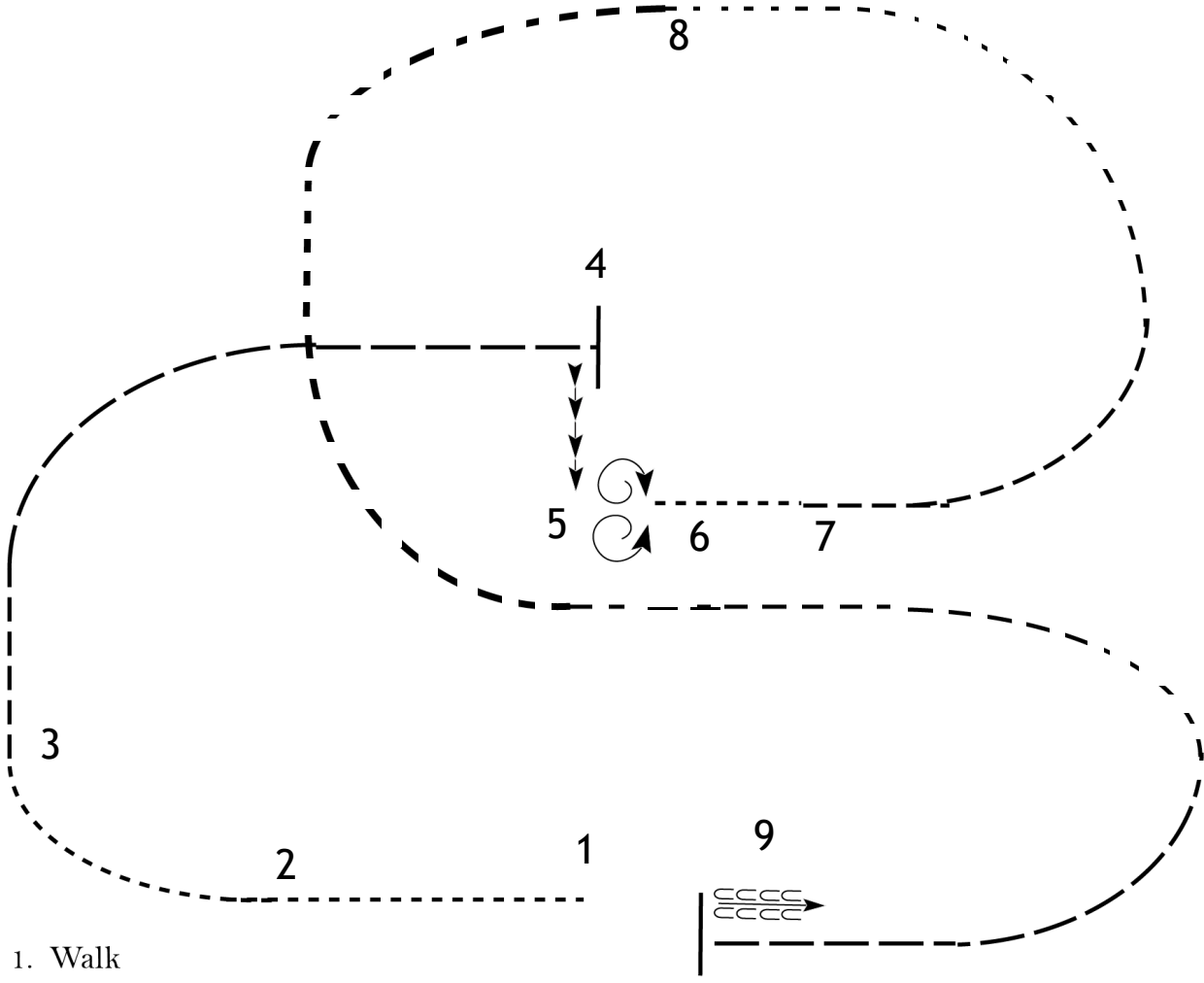

1. Walk
2. Trot
3. Extend alongside of the arena and around the corner to center.
4. Stop, side pass right
5. 360 degree turn each direction (either way 1st)
6. Walk.
7. Trot.
8. Extend the trot
9. Stop & Back

Walk	-----
Jog	- - - - -
Extended Jog	— — — — —
Lope	
Lead Change	⌘
Back	← ⊞ ⊞ ⊞ ⊞
Marker	Ⓚ

[RR/3]

Pattern Provided by:

TUSS MARCH 2025

RANCH RIDING (GREEN HORSE OR RIDER, YOUTH OR NON PRO)

Show Date:

www.HorseShowPatterns.com

www.HorseShowPatterns.com

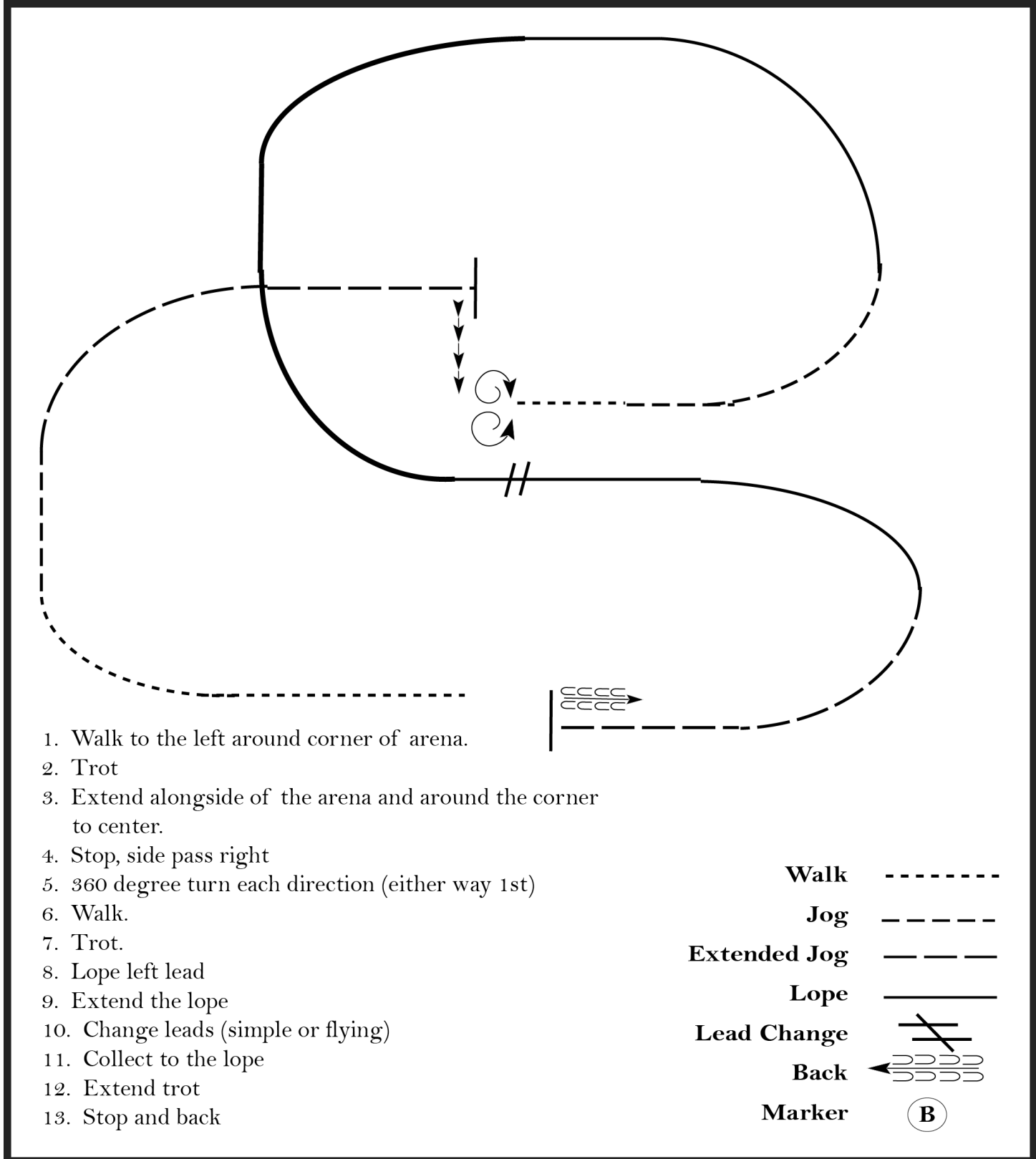

1. Walk to the left around corner of arena.
2. Trot
3. Extend alongside of the arena and around the corner to center.
4. Stop, side pass right
5. 360 degree turn each direction (either way 1st)
6. Walk.
7. Trot.
8. Lope left lead
9. Extend the lope
10. Change leads (simple or flying)
11. Collect to the lope
12. Extend trot
13. Stop and back

Walk
Jog	-----
Extended Jog	-----
Lope	—————
Lead Change	———/———
Back	←—————
Marker	ⓑ

[RR/3]

Pattern Provided by:

TUSS MARCH 2025

W/T ENGLISH EQUITATION (15 & UNDER 16 & OVER)

Show Date:

w w w . H o r s e S h o w P a t t e r n s . c o m

w w w . H o r s e S h o w P a t t e r n s . c o m

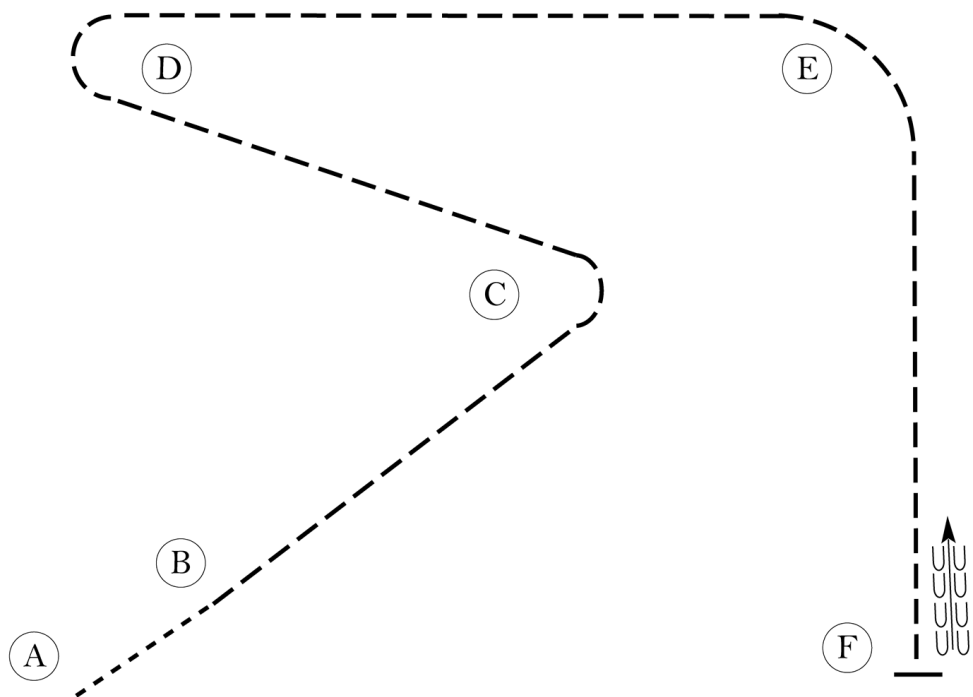

Be ready before A.

1. Walk A to B.
2. Posting trot on the left diagonal to C.
3. Change diagonals and post on the right diagonal to D.
4. Sitting trot from D to E.
5. Trot on the left diagonal E to F.
6. Halt at F and back approximately one horse length.

Follow the instructions of your ring steward.

Walk	-----
Trot	- - - - -
Extended Trot	-----
Canter	—————
Leg Yield	
Lead Change	↘ ↘ ↘
Back	← ← ←
Marker	⊙
Sidepass	← →
Hand Gallop	—————

[HSE/WT-64]

Pattern Provided by:

TUSS MARCH 2025

WESTERN RIDING (OPEN)

Show Date:

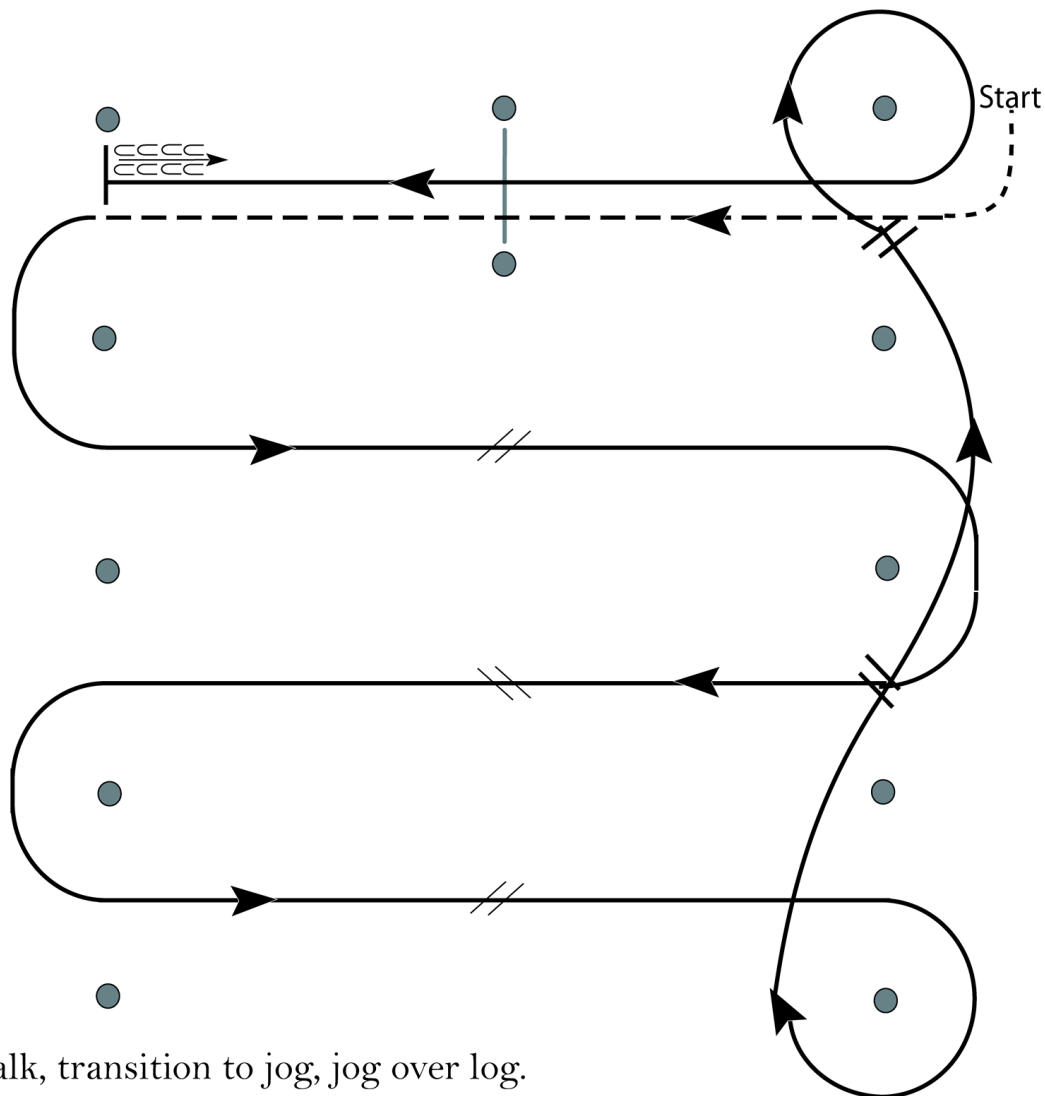

1. Walk, transition to jog, jog over log.
2. Transition to left lead lope.
3. First crossing change.
4. Second crossing change.
5. Third crossing change.
6. Circle and first line change.
7. Second line change and circle.
8. Lope log.
9. Stop and back.

[WR/GP-2]

Pattern Provided by:

TUSS MARCH 2025

WESTERN EQUITATION (OPEN)

Show Date:

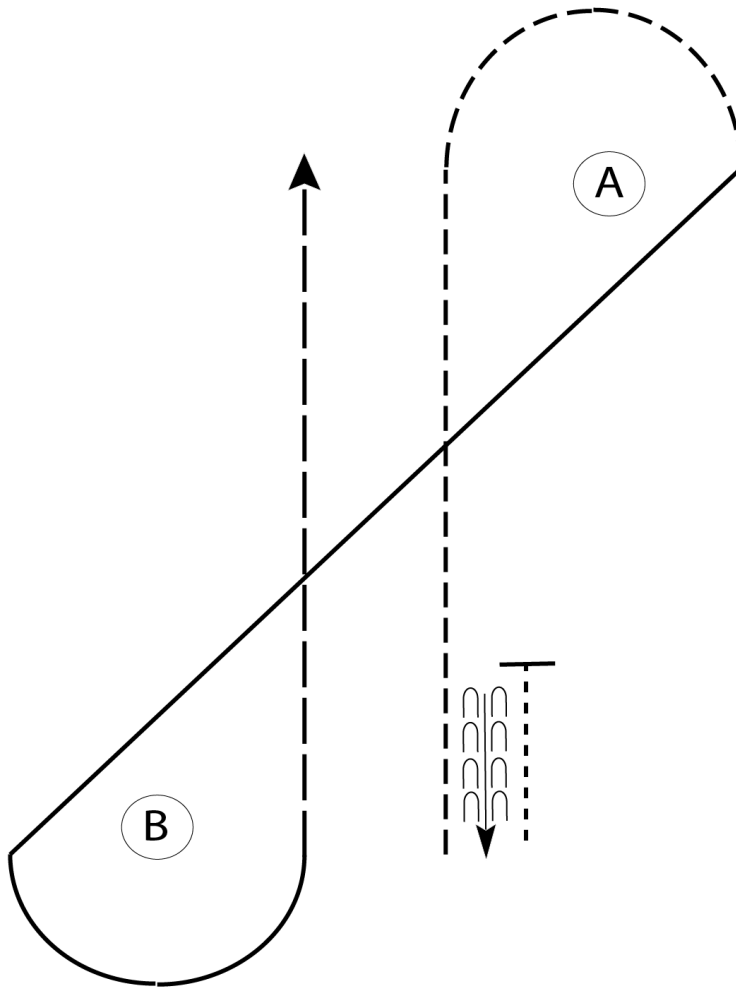

Be ready lined up to A.

1. Walk approximately 2 horse lengths toward A.
2. Stop and back until even with B.
3. Jog to and around A.
4. Lope on the left lead to and around B.
5. Extended jog in a straight line.
6. Pattern is over once you have passed A.

Follow the instructions of your ring steward.

Walk	-----
Jog	- - - - -
Extended Jog	- - - - -
Lope	—————
Lead Change	⋈
Back	←←←←←
Marker	⊙ B

[WH/1-92]

Pattern Provided by:

w w w . H o r s e S h o w P a t t e r n s . c o m

w w w . H o r s e S h o w P a t t e r n s . c o m

TUSS MARCH 2025

W/T WESTERN EQUITATION (15 & UNDER 16 & OVER)

Show Date:





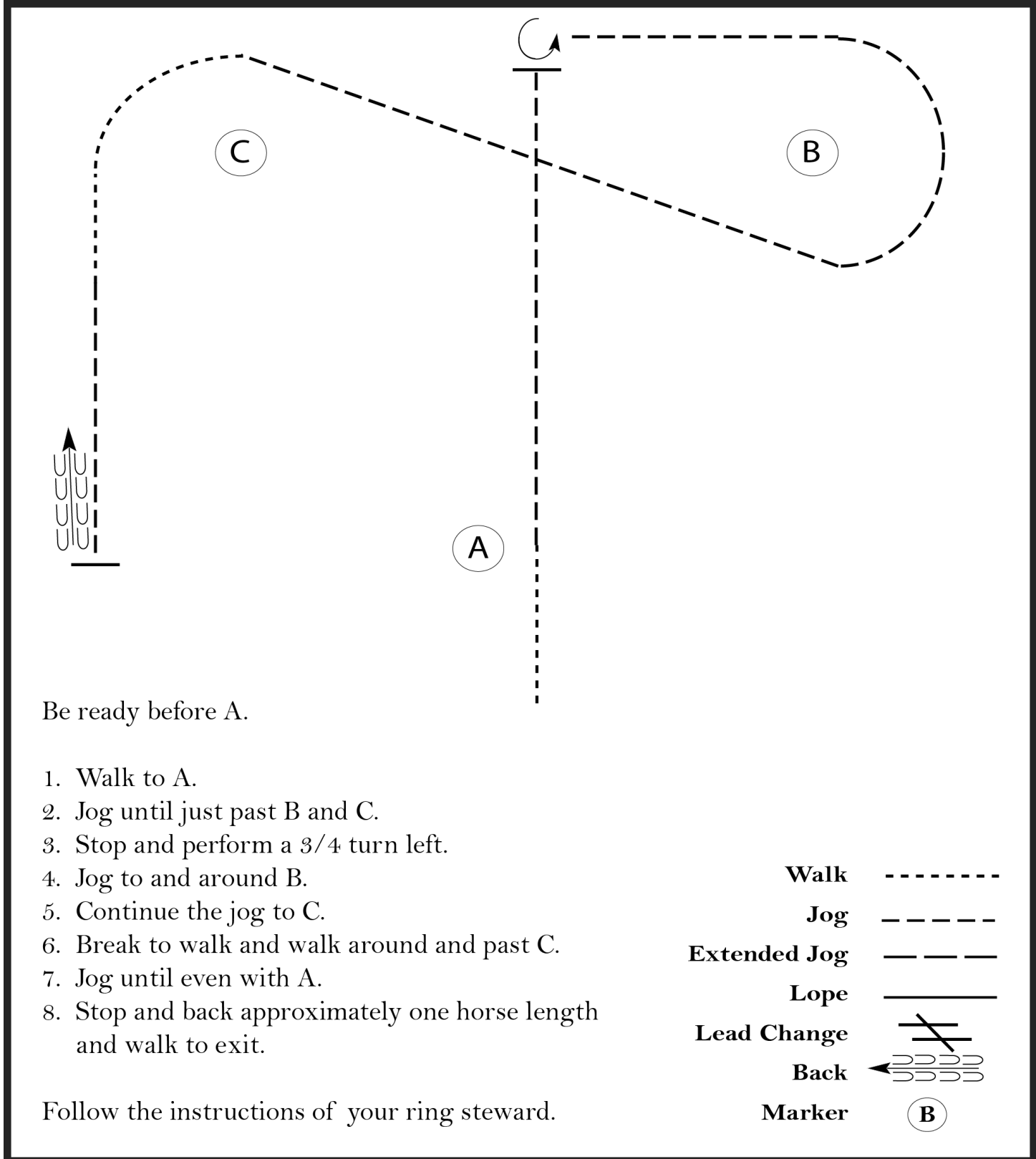

w w w . H o r s e S h o w P a t t e r n s . c o m

w w w . H o r s e S h o w P a t t e r n s . c o m

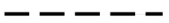

Be ready before A.

1. Walk to A.
2. Jog until just past B and C.
3. Stop and perform a 3/4 turn left.
4. Jog to and around B.
5. Continue the jog to C.
6. Break to walk and walk around and past C.
7. Jog until even with A.
8. Stop and back approximately one horse length and walk to exit.

- Walk 
- Jog 
- Extended Jog 
- Lope 
- Lead Change 
- Back 
- Marker 

Follow the instructions of your ring steward.

[WH/WT-91]

Pattern Provided by:

TUSS MARCH 2025

ENGLISH EQUITATION (OPEN)

Show Date:

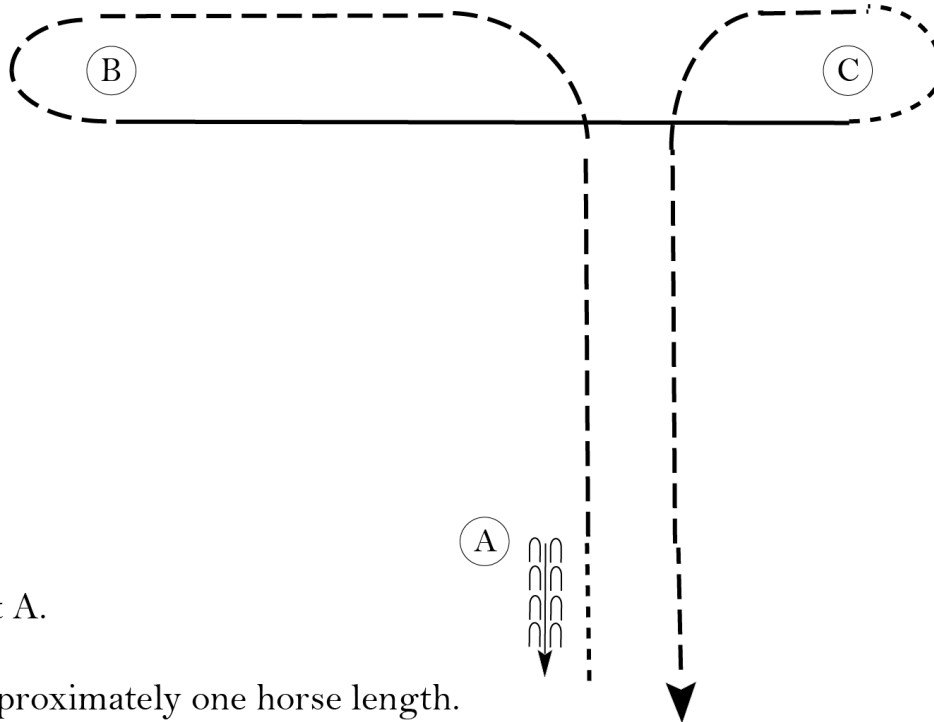

Be ready at A.

1. Back approximately one horse length.
2. Walk to A.
3. Trot on the left diagonal to top of pattern.
4. Change diagonal and trot on the right diagonal trot to and around B.
5. Canter on the right lead to C.
6. Walk around C.
7. Trot on the right diagonal until even with A.
8. Continue to trot and trot to exit.

Follow the instructions of your ring steward.

Walk	-----
Trot	- - - - -
Extended Trot	-----
Canter	—————
Leg Yield	
Lead Change	↙ ↘
Back	← ← ← ← ←
Marker	⊙
Sidepass	← - - - - →
Hand Gallop	—————

[HSE/1-70]

Pattern Provided by:

w w w . H o r s e S h o w P a t t e r n s . c o m

w w w . H o r s e S h o w P a t t e r n s . c o m

TUSS MARCH 2025

SHOWMANSHIP (OPEN)

Show Date:

w w w . H o r s e S h o w P a t t e r n s . c o m

w w w . H o r s e S h o w P a t t e r n s . c o m

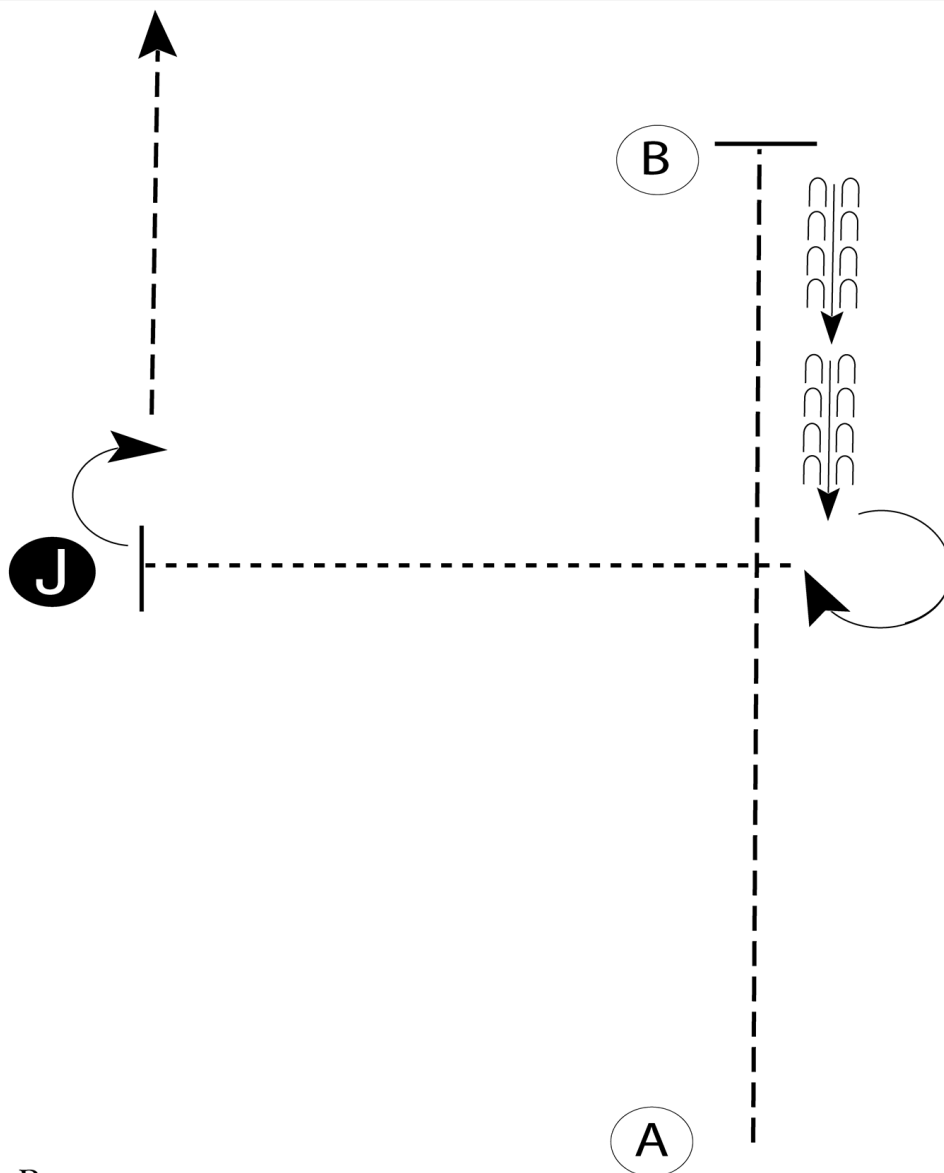

1. Trot A to B.
2. Stop at B.
3. Back halfway to A.
4. Perform a 270 degree turn .
5. Walk to the judge, stop and set up for inspection.
6. When dismissed, perform a 90 degree turn and trot away from judge.

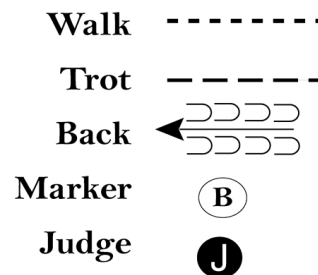

Follow the instructions of your ring steward.

[SWT-1]

Pattern Provided by:

TUSS MARCH 2025

SHOWMANSHIP (WALK ONLY, 10 & UNDER)

Show Date:

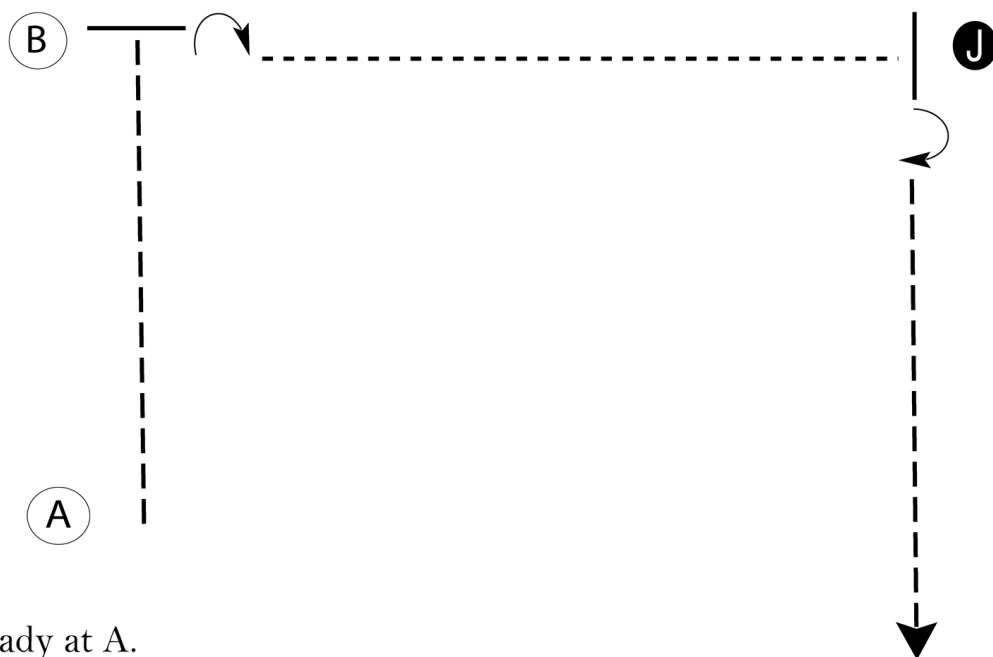

Be ready at A.

1. Trot to B and stop.
2. Perform a 90 degree turn. Walk to judge.
3. Stop, set up, inspection.
4. When dismissed, perform a 90 degree turn.
5. Trot to the line up or follow the directions of the ring steward.

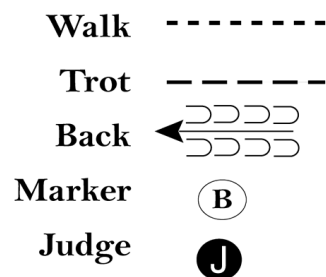

[S/WT-29]

Pattern Provided by:

TUSS MARCH 2025

SHOWMANSHIP (SHOWMANSHIP, 15 & UNDER SHOWMANSHIP 16 & OVER)

Show Date:

w w w . H o r s e S h o w P a t t e r n s . c o m

w w w . H o r s e S h o w P a t t e r n s . c o m

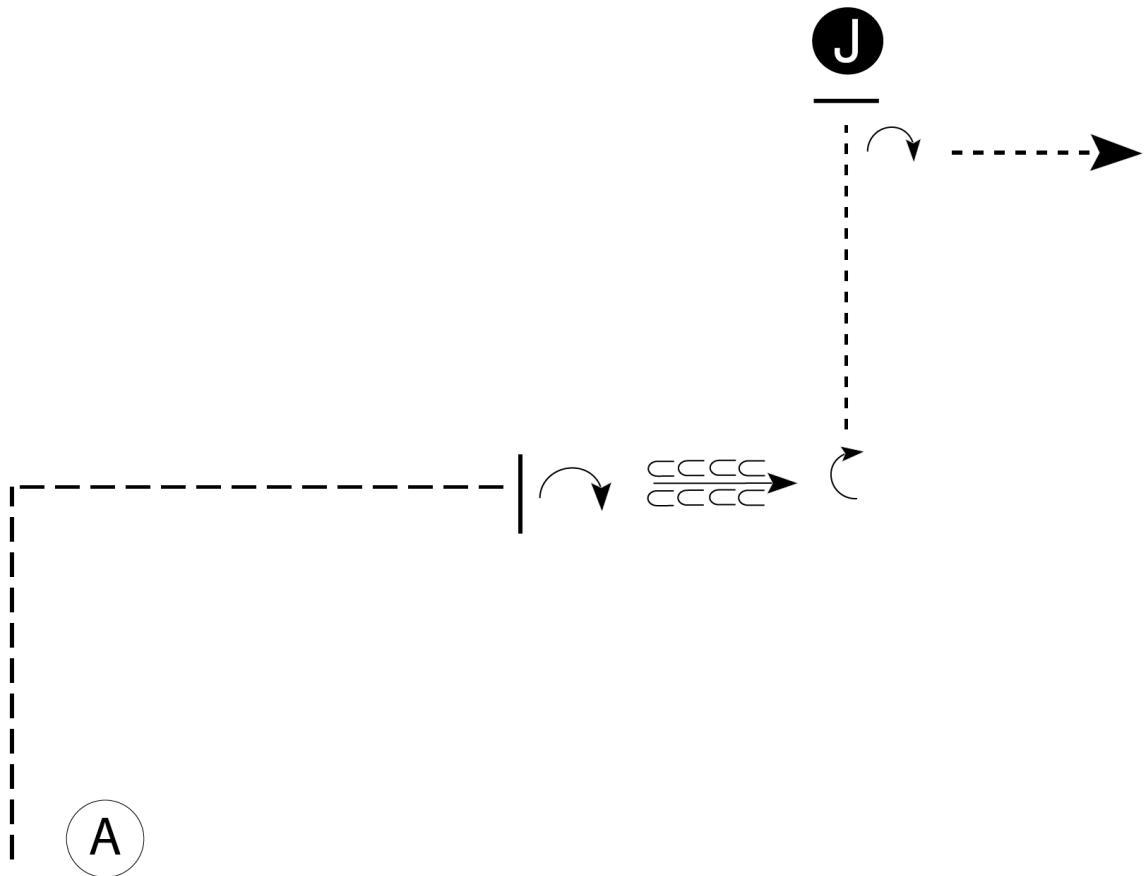

Be ready at A.

1. When acknowledged, trot a square corner to center of pattern.
2. Stop and perform a 180 degree turn.
3. Back approximately one horse length.
4. Perform a 90 degree turn.
5. Walk to Judge.
6. Stop and set up.
7. Inspection.
8. Perform a 90 degree turn and walk off.

- Walk -----
- Trot - - - - -
- Back ← 〰〰〰
- Marker (B)
- Judge (J)

[S/WT-126]

Pattern Provided by:

TUSS MARCH 2025

TRAIL (ALL AGE DIVISIONS, OPEN)

www.HorseShowPatterns.com

www.HorseShowPatterns.com

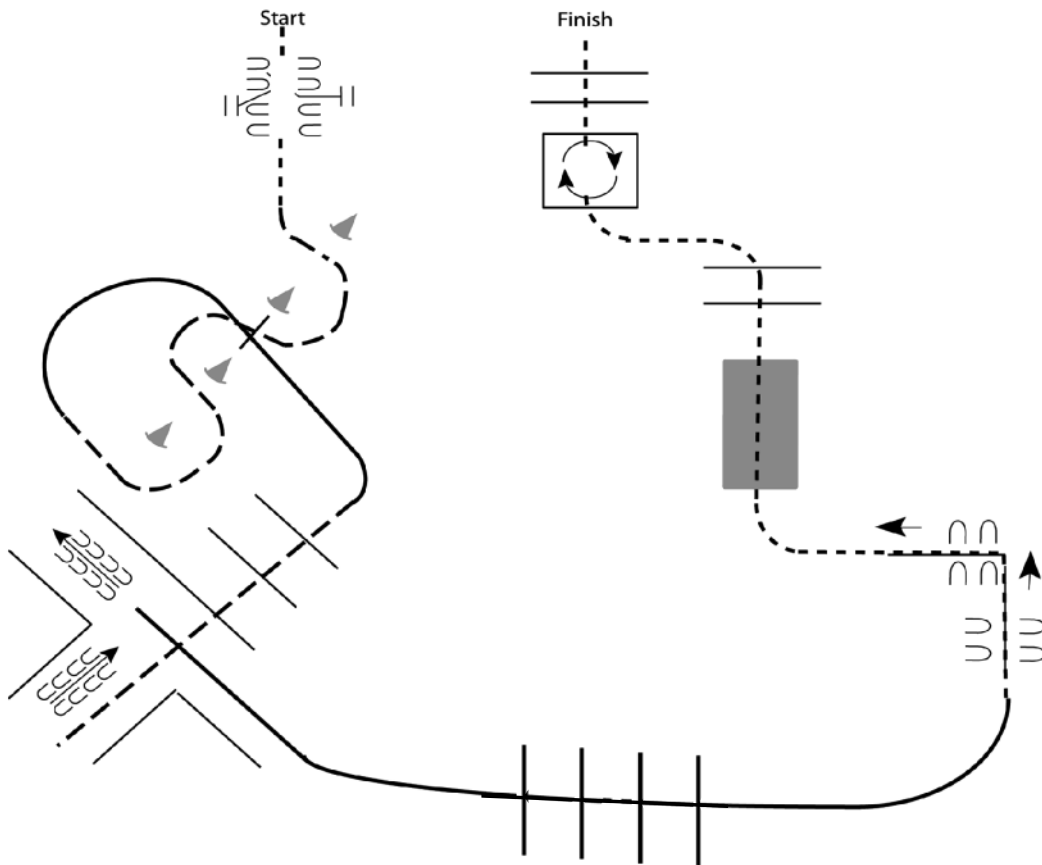

Begin at Start.

1. Walk gate.
2. Jog through cones.
3. Lope right lead to poles.
4. Jog over poles into chute.
5. Back the L.
6. Lope left lead over poles.
7. Side pass left over poles.
8. Walk over bridge, poles and into box.
9. Perform a 360 degree turn to the right, walk out of box and over poles to finish.

Walk	-----
Jog	-----
Extended Jog	-----
Lope	-----
Leg Yield	
Lead Change	
Back	←←←
Marker	Ⓚ
Sidepass	←←←

TUSS MARCH 2025

TRAIL IN HAND, WALK ONLY, 10 & UNDER, GREEN HORSE/RIDER

*Walk only = walk where it says trot

www.HorseShowPatterns.com

www.HorseShowPatterns.com

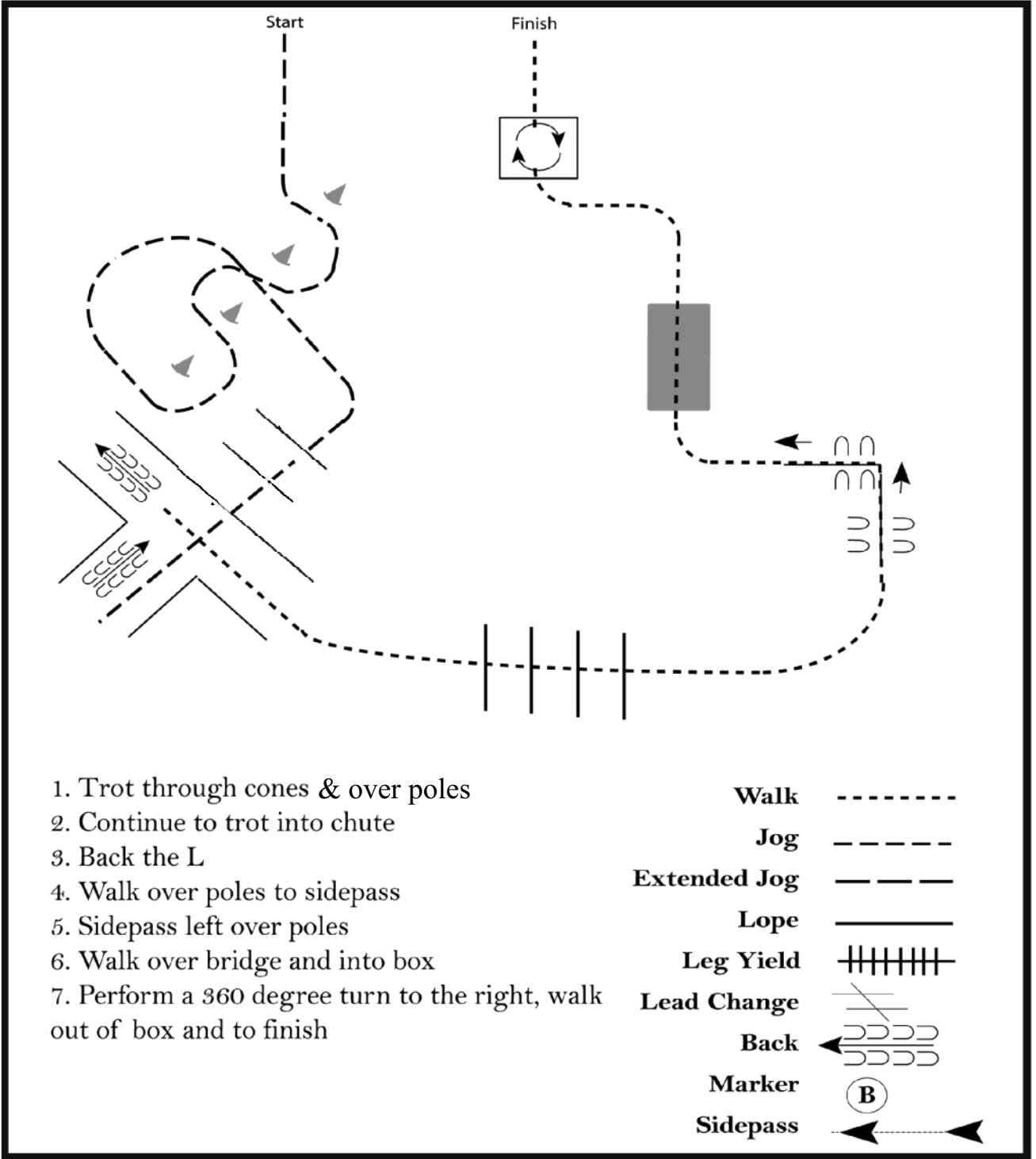

1. Trot through cones & over poles
2. Continue to trot into chute
3. Back the L
4. Walk over poles to sidepass
5. Sidepass left over poles
6. Walk over bridge and into box
7. Perform a 360 degree turn to the right, walk out of box and to finish

Walk	-----
Jog	- - - - -
Extended Jog	- - - - -
Lope	_____
Leg Yield	
Lead Change	///
Back	←←←←←
Marker	Ⓚ
Sidepass	←←←←←

TUSS MARCH 2025

TRAIL 15 & UNDER, 16 & OVER, OPEN

www.HorseShowPatterns.com

www.HorseShowPatterns.com

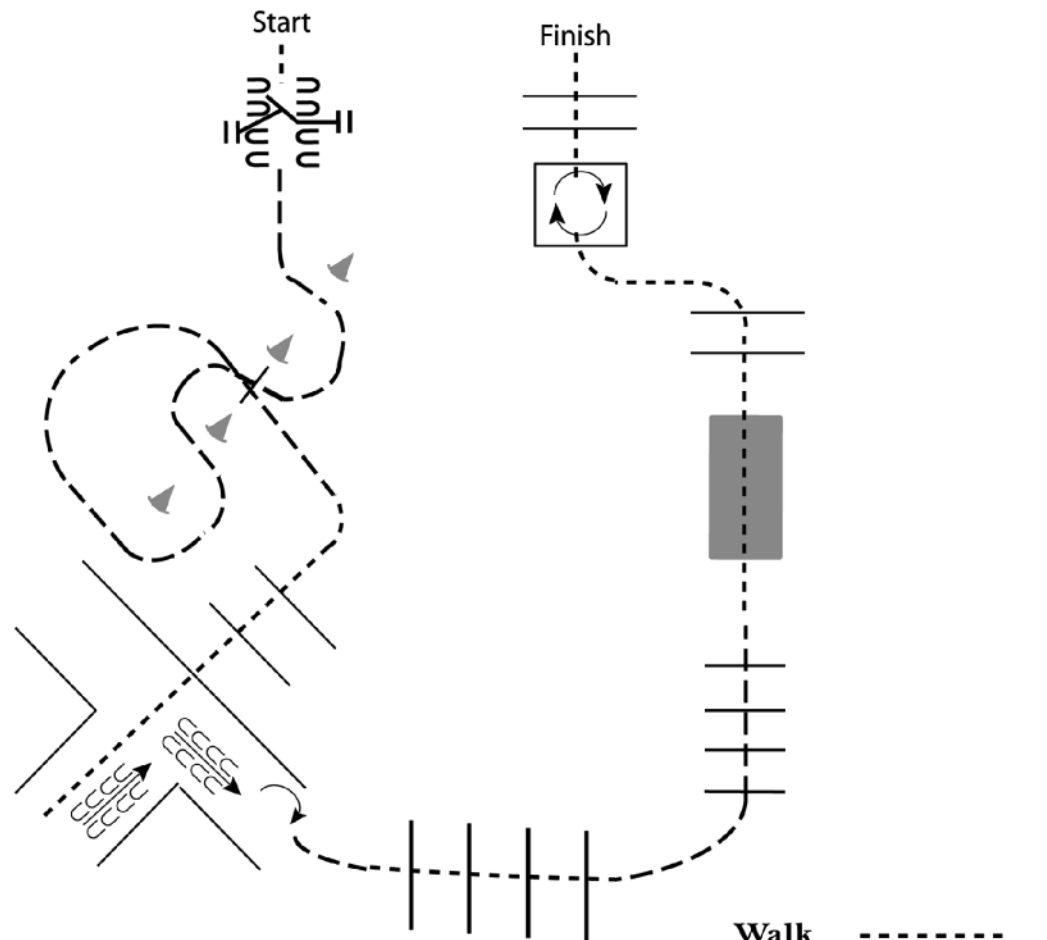

1. Walk to and work gate.
2. Jog through cones.
3. Walk over poles into chute.
4. Back out of chute; turn 180 degrees right.
5. Jog over poles to bridge.
6. Walk over bridge and poles.
7. Walk into box and perform a 360 degree turn to the right.
8. Walk out of box and over poles.

Walk	-----
Jog	- - - - -
Extended Jog	— — — — —
Lope	—————
Leg Yield	
Lead Change	///
Back	←←←←←
Marker	Ⓚ
Sidepass	←-----→

TUSS MARCH 2025

GREEN HORSE/RIDER, NOVICE RIDER

www.HorseShowPatterns.com

www.HorseShowPatterns.com

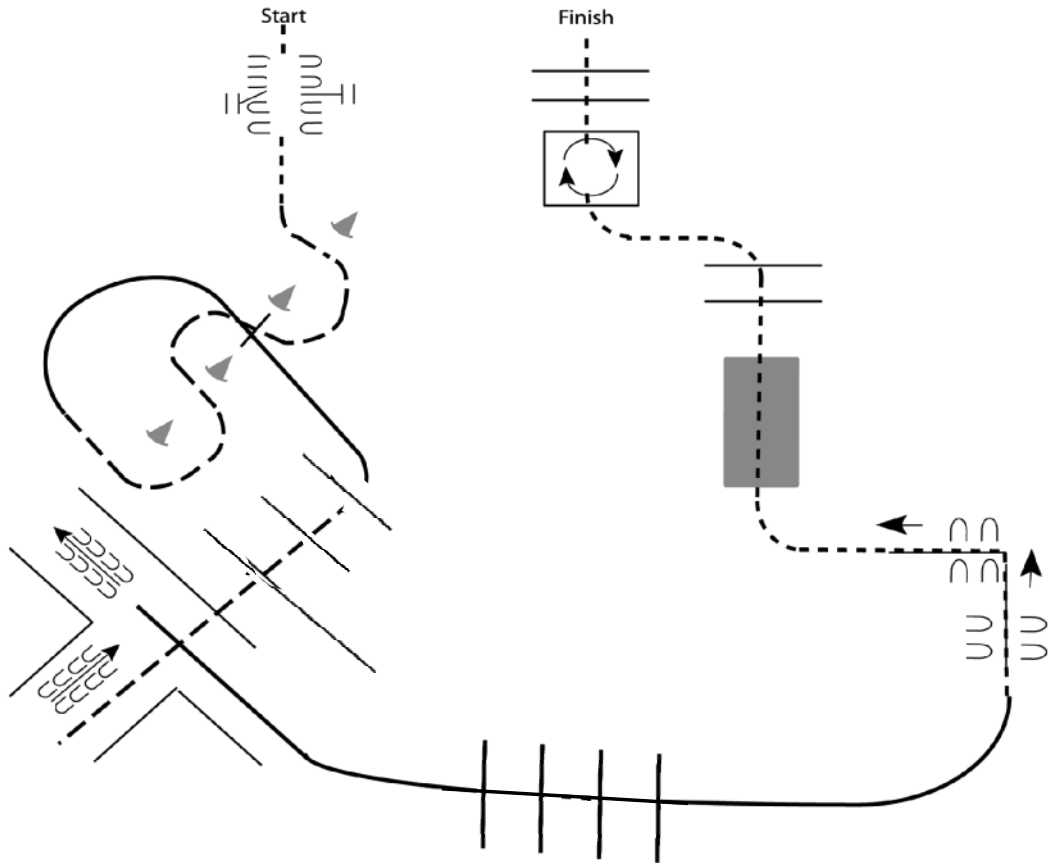

Begin at Start.

1. Walk thru gate.
2. Jog through cones.
3. Lope right lead to poles.
4. Jog over poles into chute.
5. Back the L.
6. Lope left lead over poles.
7. Side pass left over poles.
8. Walk over bridge, poles and into box.
9. Perform a 360 degree turn to the right, walk out of box and over poles to finish.

Walk	-----
Jog	- - - - -
Extended Jog	— — — —
Lope	—————
Leg Yield	
Lead Change	— / —
Back	←←←←←
Marker	ⓑ
Sidepass	←←←←←